



## Features

- Small size with high current
- SMT Type with less height
- Custom designs on request
- Rating Voltage: 250Vrms max
- Temperature range: -40°C to +125°C

## Applications

- Interferences suppression of common mode noise
- Power line filter
- Switch-mode power supplies



## ► Dimensions & Configurations (Unit:mm)

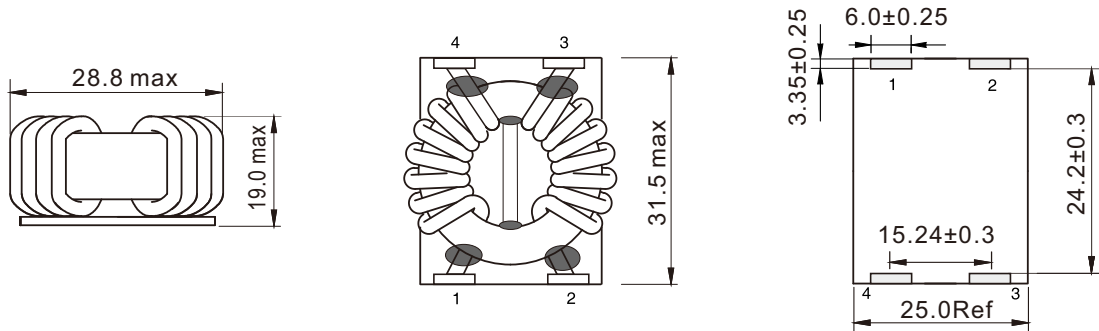

## ► Recommended Layout

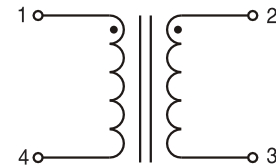
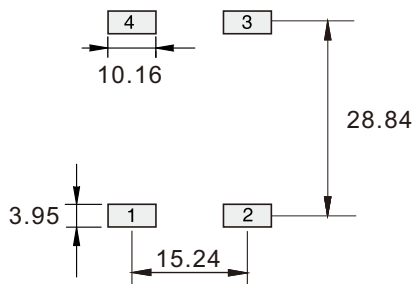

Schematic 1:1

## ► Electrical Characteristics For CMX1211 Series

Part Number	Inductance (uH)			DCR (max) [mΩ]	Rated Current (max) [A]
	Nom.	Min.	Max.		
CMX1211-681	68	40.8	91.8	0.56	50
CMX1211-181	180	108	243	1.35	32
CMX1211-321	320	192	432	2.5	28
CMX1211-601	620	372	837	3.5	20
CMX1211-801	800	480	1080	5.3	16
CMX1211-132	1300	780	1755	10	11
CMX1211-182	1800	1080	2430	14	9

- Inductance Testing: 100KHz 0.1V
- Hi-pot (Coil-Coil): 1500VAC